

Winding Type Chip Inductor Size 3225

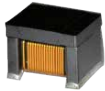

- Ferrite core wire wound construction.
- High Reliability due to wire wound type construction.
- Small footprint as well as low profile.
- 100% Lead (Pb) & Halogen-Free and RoHS compliant.
- AEC-Q200 qualified
- Operating temperature -55~+150°C
- Quantity: 1500pcs

- Inductor for use in in-vehicle PoC (Power Over Coax)

Dimensions: [mm]

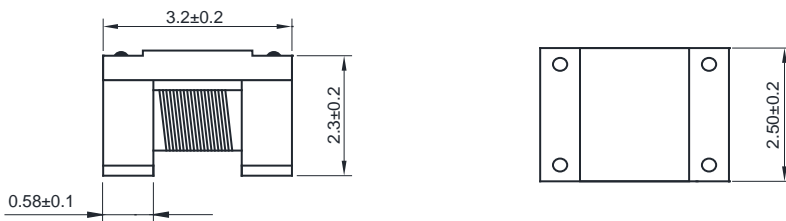

Electrical Properties:

Part No	L @ 100KHz (μ H)	Tol.	R _{DC} Max. (Ω)	I _{SAT} typ. (mA)	I _R typ. (mA)
ACMA3225POT-4R7M	4.7	±20%	0.10	720	1500
ACMA3225POT-100M	10.0	±20%	0.15	450	1300

I_{SAT}: When based on the inductance change rate (30% below the initial L value)

I_R: When based on the temperature increase (temperature increase of 40°C by self-heating)

Soldering Reflow:

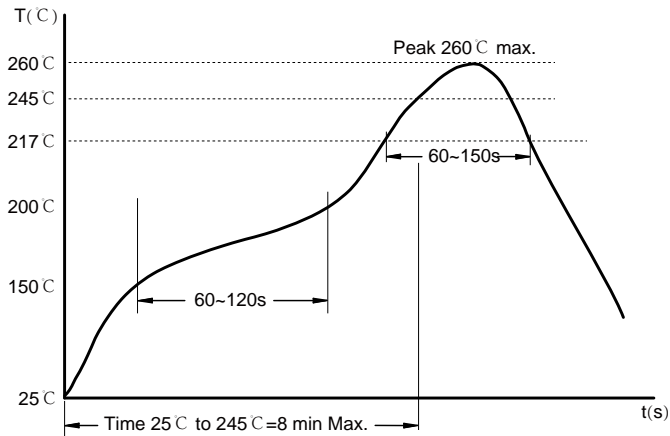

Preheat condition: 150 ~200 °C / 60~120 sec.

Allowed time above 217 °C : 60~150 sec.

Max temperature: 260 °C .

Allowed Reflow time: 3x max.

Packaging Information:

Tape Dimension :

Series	A0 (mm)	B0 (mm)	D (mm)	P0 (mm)	P1 (mm)	W (mm)	K0 (mm)	E (mm)	T (mm)
ACMA3225POT	2.70±0.1	3.50±0.1	1.5±0.1	4.0±0.1	4.0±0.1	8.0±0.3	2.75±0.1	1.75±0.1	0.30±0.05

Peel force of top cover tape:

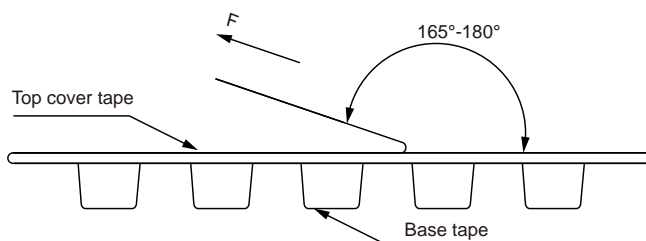

The peel force of top cover tape shall be between 0.14 to 0.78 N

Reel Dimension: [mm]

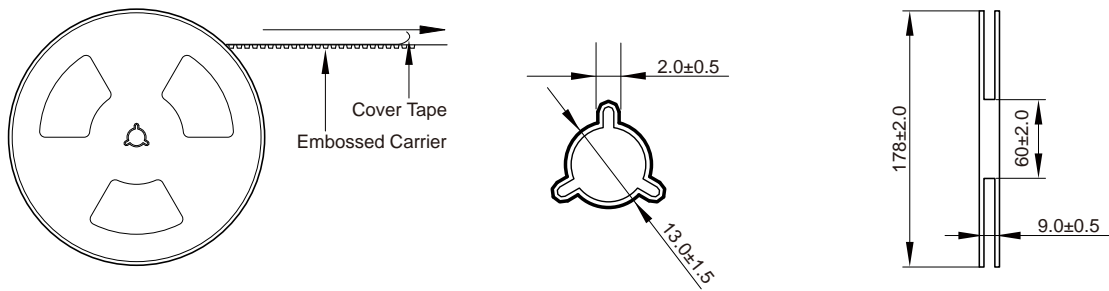

Packaging Quantity:

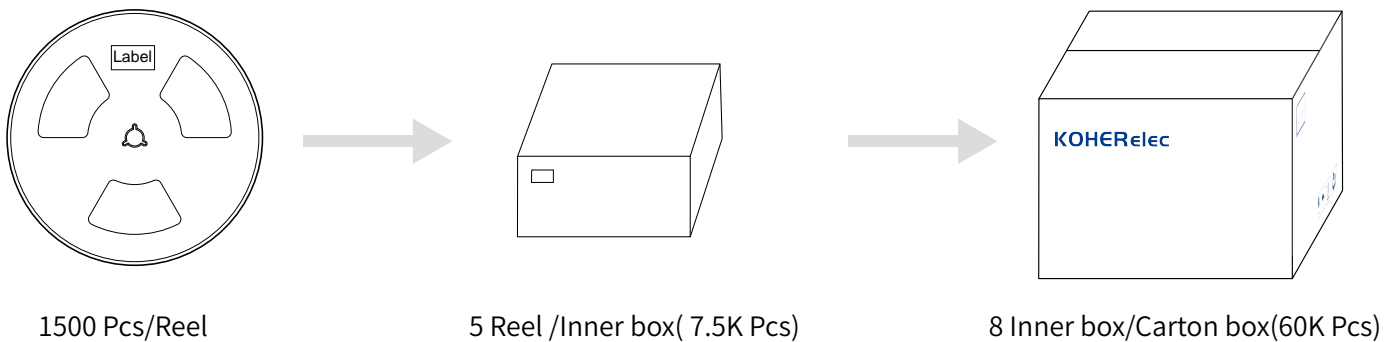

Cautions and Warnings:

Storage Conditions :

- The storage period is within 12 months after the completion of production. Be sure to follow the storage conditions (temperature: -5 to 35°C, humidity: 75% RH Max).If the storage period elapses, the soldering of the terminal electrodes may deteriorate.The warranty period is one year.
- Product should not be exposed to environment with high temperature, high humidity, dust, corrosive gas and etc.
- Products should be handled with care to avoid damage or contamination from perspiration and skin oils.
- Please always handle products carefully to prevent any damage caused by dropping down or inappropriate removing.

Operation Instructions:

- Self heating (temperature increase) occurs when the power is turned ON, so the tolerance should be sufficient for the set thermal design.
- Before soldering, be sure to preheat components.The preheating temperature should be set so that the temperature difference between the solder temperature and chip temperature does not exceed 150°C.
- Soldering corrections after mounting should be within the range of the conditions determined in the specifications.If overheated, a short circuit, performance deterioration, or lifespan shortening may occur.
- Generally, Koher might not be familiar with either customer's specific application or actual requests as customer does.As a result customer shall be responsible for checking and confirming whether Koher product with the performance described in the product specification is suitable for using in customer's particular application or not.