

ACMA POC Series

Winding Type Chip Inductor

Size 3225

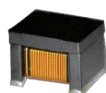

FEATURES

- Ferrite core wire wound construction.
- High Reliability due to wire wound type construction.
- Small footprint as well as low profile.
- 100% Lead(Pb) & Halogen-Free and RoHS compliant.
- AEC-Q200 qualified
- Operating temperature -55~+150°C
- Quantity: 1500pcs

APPLICATION

- Inductor for use with separate signal and power lines in in-vehicle PoC (Power Over Coax)
- Application guides: Car Infotainment

Dimensions: [mm]

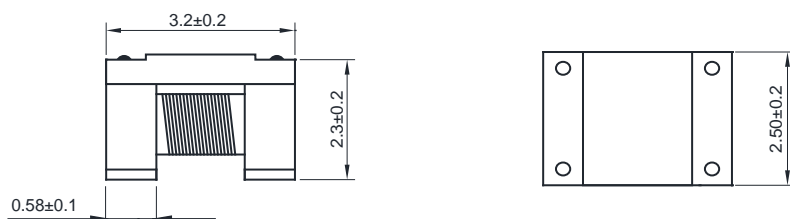

Electrical Properties:

	(μH)	DC (Ω)	(MHz)	(mA)	(mA)		
					85°C	105°C	125°C
ACMA3225POC-2R2M	2.2	0.19	200	1000	1000	880	520
ACMA3225POC-3R3M	3.3	0.24	150	950	950	840	500
ACMA3225POC-4R7M	4.7	0.28	100	850	850	720	400
ACMA3225POC-100M	10	0.40	100	500	700	620	360
ACMA3225POC-220M	22	0.62	50	400	550	500	280
ACMA3225POC-470M	47	0.90	30	300	500	300	100

ISAT: Applied the current to coils, the inductance change shall be less than 30% of initial value.

Ambient temperature (85°C/105°C): the part temperature (ambient temperature plus self-generation of heat) should be under 125°C.

Ambient temperature (125°C): the part temperature (ambient temperature plus self-generation of heat) should be under 130°C.

Soldering Reflow:

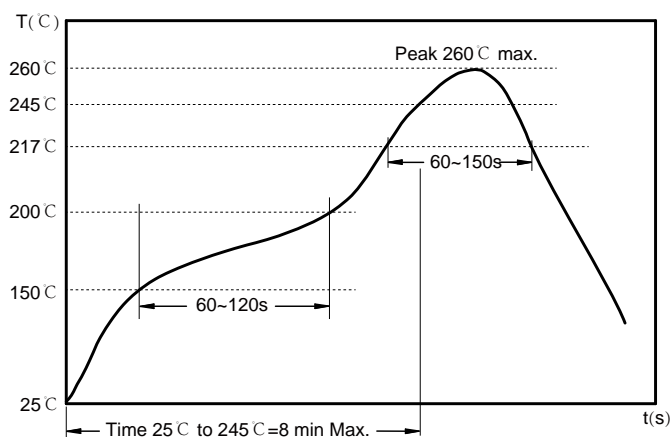

Preheat condition: 150 ~200 C / 60~120 sec.

Allowed time above 217 C : 60~150 sec.

Max temperature: 260 C .

Allowed Reflow time: 3x max.

Packaging Information:

Tape Dimension:

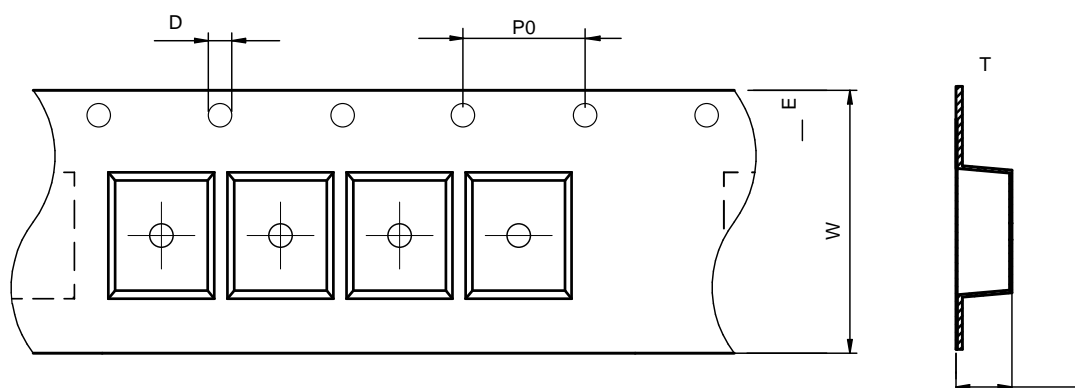

Series	A0 (mm)	B0 (mm)	D (mm)	P0 (mm)	P1 (mm)	W (mm)	K0 (mm)	E (mm)	T (mm)
ACMA3225POC	2.70±0.1	3.50±0.1	1.5±0.1	4.0±0.1	4.0±0.1	8.0±0.3	2.75±0.1	1.75±0.1	0.30±0.05

Peel force of top cover tape:

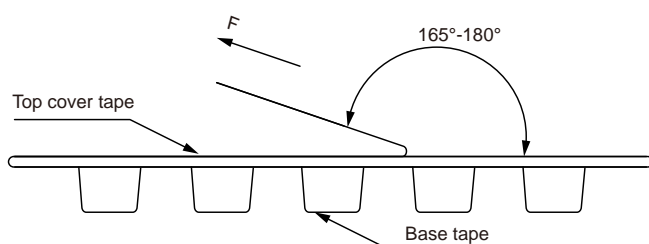

The peel force of top cover tape shall be between 0.14 to 0.78 N

Reel Dimension: [mm]

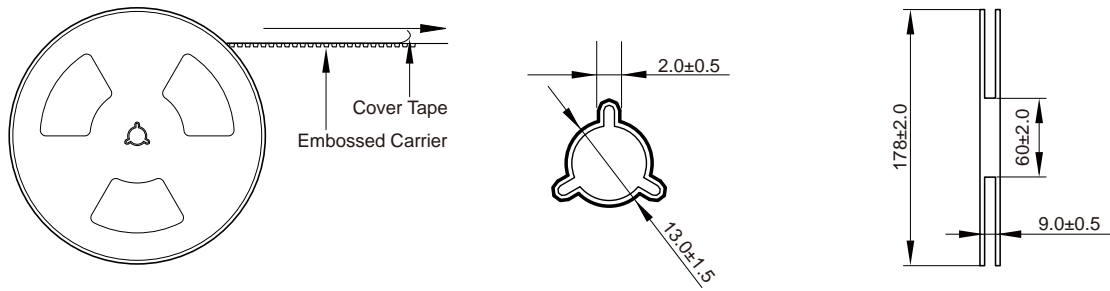

Packaging Quantity:

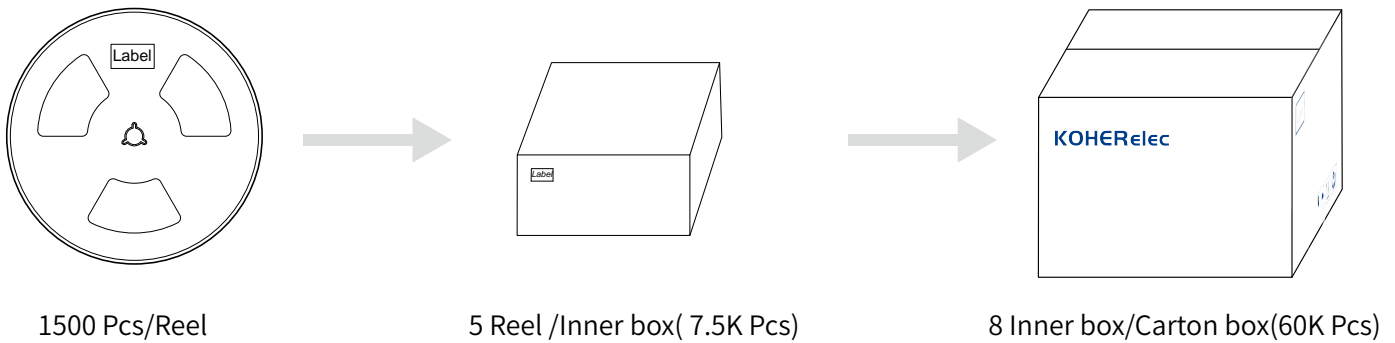

Cautions and Warnings:

Storage Conditions :

- The storage period is within 12 months after the completion of production. Be sure to follow the storage conditions (temperature: -5 to 35°C, humidity: 75% RH Max).If the storage period elapses, the soldering of the terminal electrodes may deteriorate.The warranty period is one year.
- Product should not be exposed to environment with high temperature, high humidity, dust, corrosive gas and etc.
- Products should be handled with care to avoid damage or contamination from perspiration and skin oils.
- Please always handle products carefully to prevent any damage caused by dropping down or inappropriate removing.

Operation Instructions:

- Self heating (temperature increase) occurs when the power is turned ON, so the tolerance should be sufficient for the set thermal design.
- Before soldering, be sure to preheat components.The preheating temperature should be set so that the temperature difference between the solder temperature and chip temperature does not exceed 150°C.
- Soldering corrections after mounting should be within the range of the conditions determined in the specifications.If overheated, a short circuit, performance deterioration, or lifespan shortening may occur.
- Generally, Koher might not be familiar with either customer's specific application or actual requests as customer does.As a result customer shall be responsible for checking and confirming whether Koher product with the performance described in the product specification is suitable for using in customer's particular application or not.